

# HELI



TOP1 FORKLIFT MANUFACTURING AND SALE  
IN CHINA CONTINUOUSLY FOR 20 YEARS

## 1-1.8ton LPG/DUAL FUEL FORKLIFT

LPG Forklift with Manual Transmisson CPY10, 15, 18  
LPG Forklift with Automatic Transmisson CPYD10,15,18  
Dual Fuel Forklift with Manual Transmisson CPQY10,15,18  
Dual Fuel Forklift with Automatic Transmisson CPQYD10,15,18



**CHINESE EXPORT BRAND**

Recommended  
By China Chamber of Commerce for Import and Export of Machinery  
And Electric Products



# LPG/DUAL FUEL 1-1.8 ton 3 SERIES FORKLIFT



Characteristics					
1	Manufacturer		<b>HELI</b>		
2	Model		CPY10/CPYD10 CPQY10/CPQYD10	CPY15/CPYD15 CPQY15/CPQYD15	CPY18/CPYD18 CPQY18/CPQYD18
3	Power unit		Diesel		
4	Rated Capacity	Q(kg)	1000	1500	1750
5	Load Center	C(mm)	500		
6	Operation		Seated		
7	Overall Max.lifting height(with backrest)	h4(mm)	4017	4014	4014
8	Max.Lifting height	h3(mm)	3000		
9	Free lift height	h2(mm)	150	155	155
10	Height mast retracted(uptight)	h1(mm)	1995	1995	1995
Dimensions					
11	Overall height(overhead guard)	h6(mm)	2140	2140	2140
12	Overall length(with forks)	L1(mm)	2936	3150	3193
13	Overall length(without forks)	L2(mm)	2166	2230	2273
14	Overall width	B(mm)	1075	1075	1090
15	Front overhang	X(mm)	401	405	408
16	Rear overhang	L4(mm)	355	415	455
17	Wheel base	L5(mm)	1410	1410	1410
18	Min.ground clearance under mast	m1(mm)	110	110	110
19	Tread(front/rear)	R1/P(mm)	900/930	900/930	930/930
20	Outside turning radius	Wa(mm)	1870	1950	1980
21	Min.intersecting aisle	Ra(mm)	1945	2025	2055
22	Tilting angles(forward/backward)	$\alpha / \beta (^{\circ})$	5° / 10°		
23	Fork dimensions(a × b × c)	mm	770 × 100 × 32	920 × 100 × 35	920 × 100 × 35
Performance					
24	Max. Travelling speeds(With/Without load)	km/h	17/18		
25	Lifting Speeds(With/Without load)	mm/s	590/650		
26	Lowering Speeds(With/Without load)	mm/s	450/550		
27	Max. Draw-bar pull,(With/Without load)	kN	14.2/6.9		
28	Max. Negotiable Gradient(With/Without load)	%	37/22	27/18	24/17
29	Battery (Voltage/Capacity)	V/Ah	12/60		
30	Tyre size(front/rear)		Pneumatic 6.50-10-10PR/5.00-8-8PR		
31	Service Mass	kg	2300	2760	2970
Engine					
32	Internal Combustion Engine Model		Nissan K15		
33	Internal Combustion Engine Rated Output	kW/rpm	23.6/2400		
34	Internal Combustion Engine Rated Torque	Nm/rpm	103/1600		
35	Internal Combustion Engine Displacement	L	1.468		
36	Internal Combustion Engine Fuel Tank Capacity	L	46		
37	Transmission Number of Speed Fwd/Bwd type		1-1Power Shift T/M		

Engine Model and Main Specification for Option				
Internal Combustion Engine Model	Internal Combustion Engine Rated horse power	Internal Combustion Engine Rate torque	Internal Combustion Engine Displacement	Internal Combustion Engine Number of Clinder
NISSAN K21	31.2/2250	143.7/1600	2.065	4

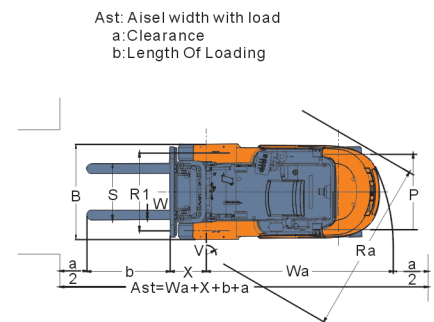
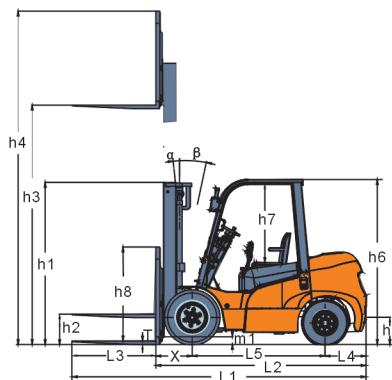
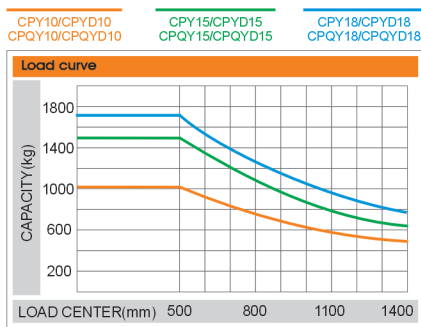

**ANHUI HELI CO., LTD.**  
 ADD 15 WEST WANGJIANG ROAD, HEFEI, ANHUI, P.R. CHINA  
 TEL (86 551)3639068, 3639258, 3639358  
 FAX (86 551)3639966  
 WEBSITE <http://www.helichina.com>

\* Details of specifications and equipment are based on information available at the time of printing and may change without notice.

AUTHORIZED DEALER

# HELI



NO.1 FORKLIFT MANUFACTURING AND SALE  
IN CHINA CONTINUOUSLY FOR 20 YEARS

## 2-3.5 ton LPG/DUAL FUEL FORKLIFT

LPG Forklift with Manual Transmisson CPY20, 25, 30, 35  
LPG Forklift with Automatic Transmisson CPYD20, 25, 30, 35  
Dual Fuel Forklift with Manual Transmisson CPQY20, 25, 30, 35  
Dual Fuel Forklift with Automatic Transmisson CPQYD20, 25, 30, 35



**S** SERIES Reliable forklift

**CHINESE EXPORT BRAND**

Recommended  
By China Chamber of Commerce for Import and Export of Machinery  
And Electric Products



# LPG/DUAL FUEL FORKLIFT 2-3.5 ton 9 SERIES



Characteristics						
1	Manufacturer		<b>HELI</b>			
2	Model		CPY20/CPYD20	CPY25/CPYD25	CPY30/CPYD30	CPY35/CPYD35
			CPQY20/CPQYD20	CPQY25/CPQYD25	CPQY30/CPQYD30	CPQY35/CPQYD35
3	Power unit		LPG/Dual Fuel			
4	Rated Capacity	Q(kg)	2000	2500	3000	3500
5	Load Center	C(mm)	500			
6	Operation		Seated			
7	Overall Max.lifting height(with backrest)	h4(mm)	4004		4182	4177
8	Max.Lifting height	h3(mm)	3000			
9	Free lift height	h2(mm)	145		145	150
10	Height mast retracted(upright)	h1(mm)	2000	2000	2075	2180
Dimensions						
11	Overall height(overhead guard)	h6(mm)	2140	2140	2170	2170
12	Overall length(with forks)	L1(mm)	3430	3650	3770	3840
13	Overall length(without forks)	L2(mm)	2510	2580	2700	2770
14	Overall width	B(mm)	1150	1150	1225	1285
15	Front overhang	X(mm)	470	470	475	485
16	Rear overhang	L4(mm)	440	510	525	585
17	Wheel base	L5(mm)	1600	1600	1700	1700
18	Min.ground clearance under mast	m1(mm)	110	110	135	135
19	Tread(front/rear)	R1/P(mm)	1970	1970	1000/970	1060/970
20	Outside turning radius	Wa(mm)	2170	2240	2400	2420
21	Min.intersecting aisle	Ra(mm)	2200	2280	2380	2400
22	Tilting angles(forward/backward)	$\alpha / \beta (^{\circ})$	$6^{\circ} / 12^{\circ}$			
23	Fork dimensions(a×b×c)	mm	920×100×45	1070×100×45	1070×125×45	1070×125×50
Performance						
24	Max. Travelling speeds(With/Without load)	km/h	17/19		18/19	19/19
25	Lifting Speeds(With/Without load)	mm/s	550/600		500/550	450/480
26	Lowering Speeds(With/Without load)	mm/s	450			
27	Max. Draw-bar pull,(With/Without load)	kN	16.4/8.3		14.5/9.8	16.5/9.8
28	Max. Gradeability ( laden/unladen)	%	26/20	24/18	23/20	20/18
29	Battery (Voltage/Capacity)	V/Ah	12/60			
30	Tyre size(front)		7.00-12-12PR		28×9-15-12PR	28×9-15-14PR
31	Tyre size(rear)		6.00-9-10PR		6.50-10-10PR	6.50-10-10PR
32	Total Weight	kg	3480	3800	4400	5000
Engine						
33	Internal Combustion Engine Model		Nissan K21		Nissan K25	
34	Internal Combustion Engine Rated Output	kW/rpm	31.2/2250		37.6/2400	
35	Internal Combustion Engine Rated Torque	Nm/rpm	143.7/1600		176.5/1600	
36	Internal Combustion Engine Displacement	L	2.065		2.488	
37	Internal Combustion Engine Fuel Tank Capacity	L	66		70	
38	Transmission Number of Speed Fwd/Bwd type		1-1 Power Shift/ 2-2 Manual shift			

CPY20/CPYD20    CPY25/CPYD25    CPY30/CPYD30    CPY35/CPYD35  
CPQY20/CPQYD20    CPQY25/CPQYD25    CPQY30/CPQYD30    CPQY35/CPQYD35

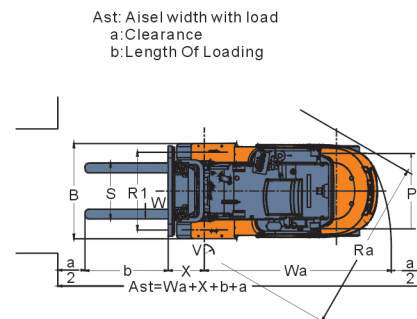
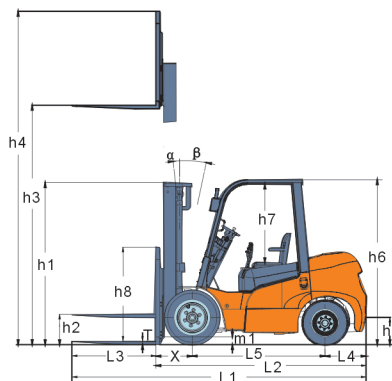
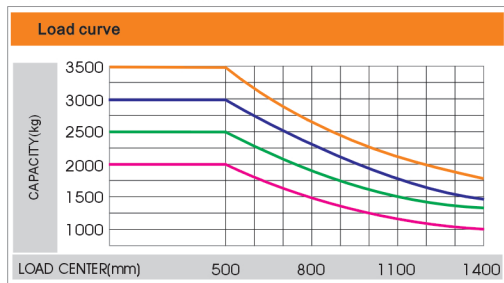

## ANHUI HELI CO., LTD.

ADD 15 WEST WANGJIANG ROAD, HEFEI, ANHUI, P.R. CHINA  
 TEL (86 551)3639068, 3639258, 3639358  
 FAX (86 551)3639966  
 WEBSITE <http://www.helichina.com>

\* Details of specifications and equipment are based on information available at the time of printing and may change without notice.

AUTHORIZED DEALER